

**5 Ton Heat Pump Outdoor Unit - 208/230 VAC, 1-Phase, 60Hz  
AOU60RLAVM**

<b>Job Name</b> _____	<b>Date</b> _____
<b>Location</b> _____	<b>Approval</b> _____
<b>Engineer</b> _____	<b>Construction</b> _____
<b>Submitted To</b> _____	<b>Unit No</b> _____
<b>Submitted By</b> _____	<b>Drawing No</b> _____
<b>Reference</b> _____	

- Energy efficient Single-Phase VRF
- Inverter driven dual rotary compressor
- High power dual DC fan motor.
- Large Blue fin heat-exchanger
- 10 Year warranty on parts and compressor. See Warranty Statement for details.
- Optional: Internet, BACnet, LonWorks, or Modbus communication.



CAPACITY	
Nominal Cooling Capacity - BTU/h [kW]	60,000 [17.58]
Nominal Heating Capacity - BTU/h [kW]	66,000 [19.34]
Nominal Tonnage - Ton(s)	5
Maximum Connectable Indoor Units	9
Connectable Capacity	50% to 130%
Cooling Power Input - kW	5.43
Heating Power Input - kW	5.17

OPERATING TEMPERATURES	
Operating Temp. Cooling (DB) - °F [°C]	23 to 115 [-5 to 46]
Operating Temp. Heating (DB) - °F [°C]	-4 to 70 [-20 to 21]

ELECTRICAL	
Electrical Power Requirements	208/230 VAC, 1-Phase, 60Hz
Voltage Range	187 to 253 VAC
Maximum Circuit Breaker - A	40
Minimum Circuit Ampacity (MCA) - A	37
Cooling Power Input - kW	5.43
Heating Power Input - kW	5.17

EFFICIENCY	
EER Cooling (Ducted/Non Ducted)	10.4 / 10.8
SEER Cooling (Ducted/Non Ducted)	16.5 / 18.5
COP / High Heating 47°F (Ducted/Non Ducted)	3.60 / 3.64
HSPF Heating (Ducted/Non Ducted)	11.0 / 11.3

COMPRESSOR	
Compressor Type	Rotary Inverter
Refrigerant Type	R410A
Refrigerant Charge - lbs [kg]	11.7 [5.3]
Compressor Crankcase Heater - W	25
Refrigerant Oil / Lubricant	POE
Compressor Capacity Control - Steps/Range	81 / 20-100%

WIRING	
Communication Cable	LonWorks (Fujitsu Pink Cable. See AE Bulletin 009)

FAN	
Fan Type	2x Propeller fan
Fan Airflow Rate - CFM [m3/h]	4,827 [8,200]
Fan Power Output - W	2x 111

PIPING	
Max. Total Refrigerant Line Length - ft [m]	590 [180]
Max Height Diff. (OD & ID)(Upper/Lower) - ft [m]	164/131 [50/40]
Max. Refrig. Line Length 1st Sep. tube & furthest IU - ft [m]	131 [40]
Pipe Connection Method: Liquid/Gas	Flare / Brazed
Pipe Connection: Liquid - in [mm]	3/8 [9.52]
Pipe Connection: Discharge Gas - in [mm]	3/4 [19.05]

HEAT EXCHANGER	
H. E. Pipe Type (Material)	Grooved H-pin (Copper)
H. E. Fin Tube (Material)	Corrugate (Aluminum)
H. E. Fin Surface Treatment	Corrosion resistance (Blue fin)
H. E. Fin Pitch - FPI [mm]	18 [1.45]
H. E. Rows x Stages	3 x 62
H. E. Face Area - Ft <sup>2</sup> [m <sup>2</sup> ]	13 [1.22]
H. E. Length - in [mm]	36-13/16 [935]

SOUND	
Sound Pressure Levels (Cooling/Heating) - dB(A)	57/57

WEIGHT	
Net Weight - lbs [kg]	269 [122]
Gross Weight - lbs [kg]	291 [132]

DIMENSIONS	
Dim.Net (HxWxD) - in [mm]	52-1/2 × 38-3/16 × 14-9/16 [1340 x 972 x 368]

Dim.Gross (HxWxD) - in [mm]	58-1/8 × 41-7/8 × 18-7/8 [1476 x 1064 x 478]
-----------------------------	---

CODE	
ETL	3170288
AHRI Certified	Standard 210/240

Note: Specifications are based on the following conditions:  
Cooling: Indoor temperature of 80°F (26.7°C) DB/67°F (19.4°C) WB, and outdoor temperature of 95°F (35°C) DB/75°F (23.9°C) WB. Heating: Indoor temperature of 70°F (21.1°C) DB/60°F (15.6°C) WB, and outdoor temperature of 47°F (8.3°C) DB/43°F (6.1°C) WB. Pipe length: 25ft. (7.5m), Height difference: 0ft. (0m) (Outdoor unit - indoor unit).



Fujitsu General America, Inc.  
353 Route 46 West  
Fairfield, NJ 07004  
Toll Free: (888) 888-3424  
Fax: (973) 836-0453  
www.airstagevrf.com

DIMENSIONS

Unit: In. (mm)

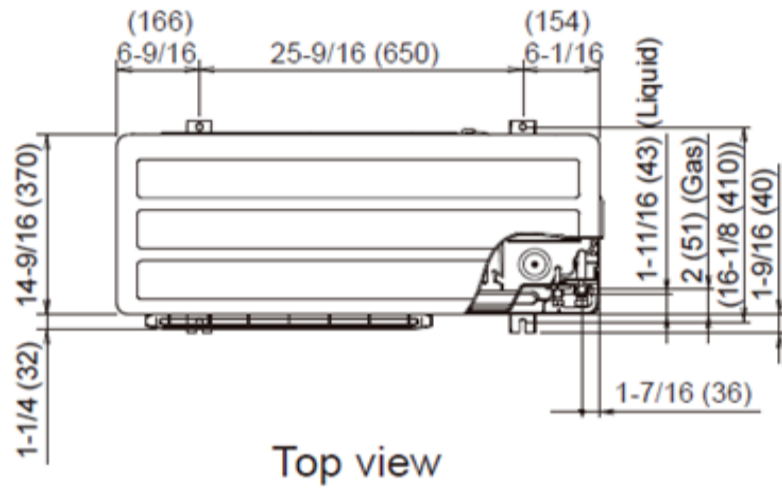

Top view

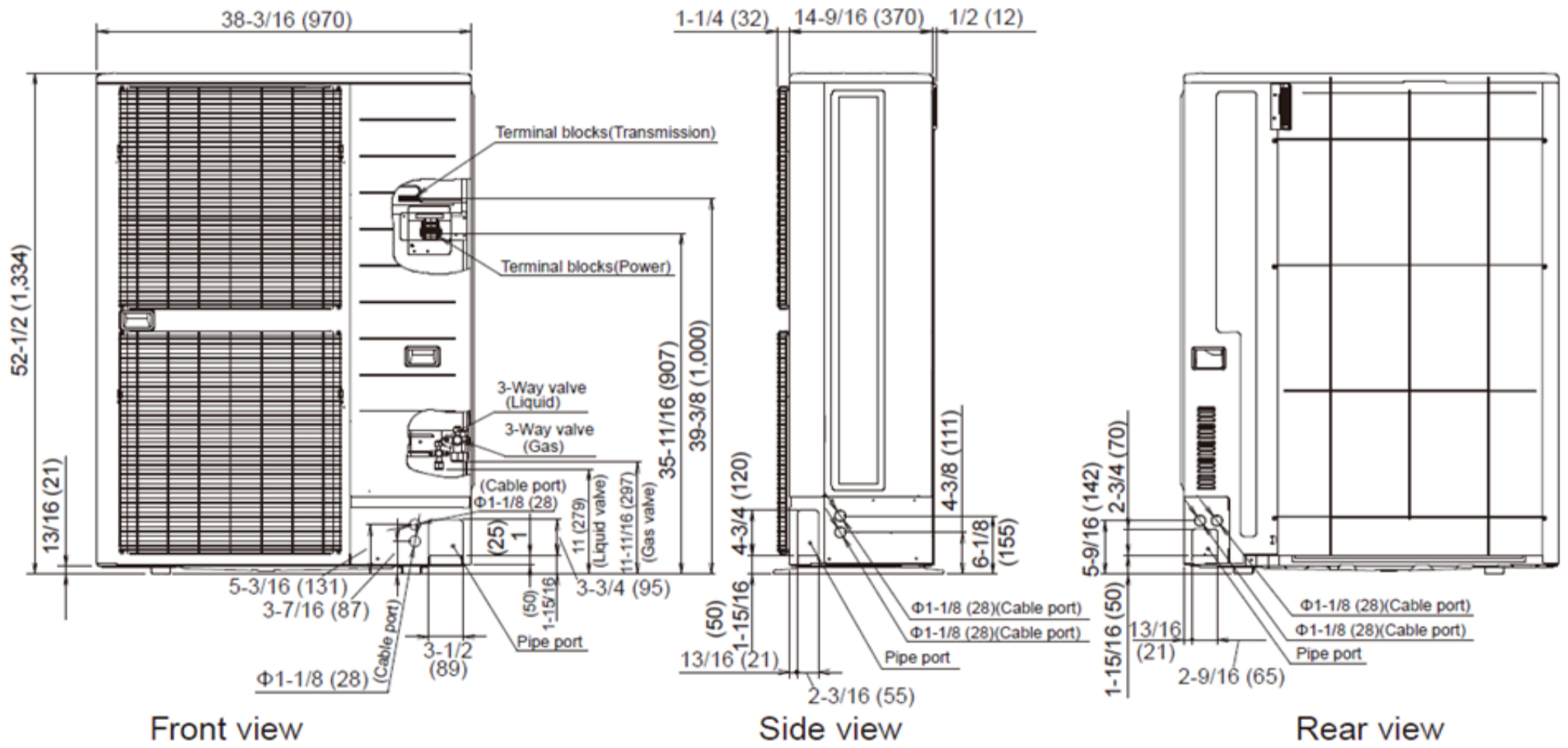

Front view

Side view

Rear view